

2005 NISSAN ELGRAND HIGHWAY STAR

Report created by hand on 2021/ /

VEHICLE DETAILS

Data Sources	USS
Reported dates	2018-
Lot number	
Chassis ID/VIN	6U9000(MNE51-
Make	NISSAN
Model	ELGRAND
Mileage	483 km
Engine CC	2500 (2.5L)
Reg. Date	2005/11
Grade/Trim	HIGHWAY STAR
Inspection	N/A
Equipment	AC
Transmission	AT
Start price	¥10,000
Finish price	Unavailable
Color	BLACK
Condition	3
Sales Status	Unknown

GRADE

3

AUTOCHECK GRADING

Poor condition

The Autocheck grading scheme is based on standard Japanese auction grading system. It lets you compare similar vehicles with ease.

Auction grade

3 Poor condition

Accident / Repair

No problem found

Mileage report

Good mileage report

Use history

Private Car

Stolen check

No stolen status



AUTOCHECK FACTS

Auction grade



Poor condition / noticeable dents & damage / rust / past repair

Odometer check



No Odometer tampering reported

NOTE: This Autocheck Vehicle History Report is based only on Information supplied to Autocheck CO. and available as of 2021-06-23 14:12:25. Other information about this vehicle, including problems, may not have been reported to Autocheck CO. Use this report as one important tool, along with a vehicle inspection and test drive, to make a better decision about your next Japanese used car.

✓ ACCIDENT / REPAIR HISTORY (JAPAN)

Type of record	Reported event	Reported date	Source	Details	Airbag
Collision	✓ Not reported				
Malfunction	✓ Not reported				
Theft	✓ Not reported				
Fire damage	✓ Not reported				
Water damage	✓ Not reported				
Hail damage	✓ Not reported				

REPORTED ODOMETER HISTORY

Reported date	Kilometres	Source
2018-██-██	██ 483 km	USS ██████

✓ USE HISTORY (JAPAN)

Use in the contaminated regions ⁴	Radioactive contamination test fail ⁵	Commercial use
Not reported	Not reported	Not reported

✓ MANUFACTURE RECALL HISTORY

Date	Source	Affected part	Details
No recall records found.			

AUCTION SHEETS & PHOTOS

Date: 2018- - Auction: USS Lot #:

7万MAXコーナー

No. [Redacted]	車歴 (商業用以外は記入)	排気量 2500	型式 CBA-ME51 NE	評価点 3
	初度登録年月 17/11月	車名 ニッサン	グレード イルグアット ハイウェイス	2WD 4WD
内装 補助評価		C		

車検	年	月	シフト	AT	修正器	S R	MAW	PS	PW
走行	[Redacted]	4	8	3	Km マイル	冷房	AC	セールスポイント	ETC バックカメラ
外色	元色	色	カラー	色	新車加算手続 (保証書付)	有・無	※車検と一緒に保管下さい		
燃料	ガソリン	軽油・()	内装色	名義変更期間	月	日			

リサイクル 預託金	15,980円	車検定員	8人	登録No.	[Redacted]
○注意事項 (検査・不具合箇所および状態等)				車台No.	ME51-[Redacted]
BOX (キー) 車名エルグアット?				シリアルNo.	[Redacted]

○検査員報告 (USS使用機)

左ミラーメカケ
シートアブレットア止め
ハンドルスレ
車内汚しキズ
左パワーサイドドア不良
マイルメーター
Rスポアセ

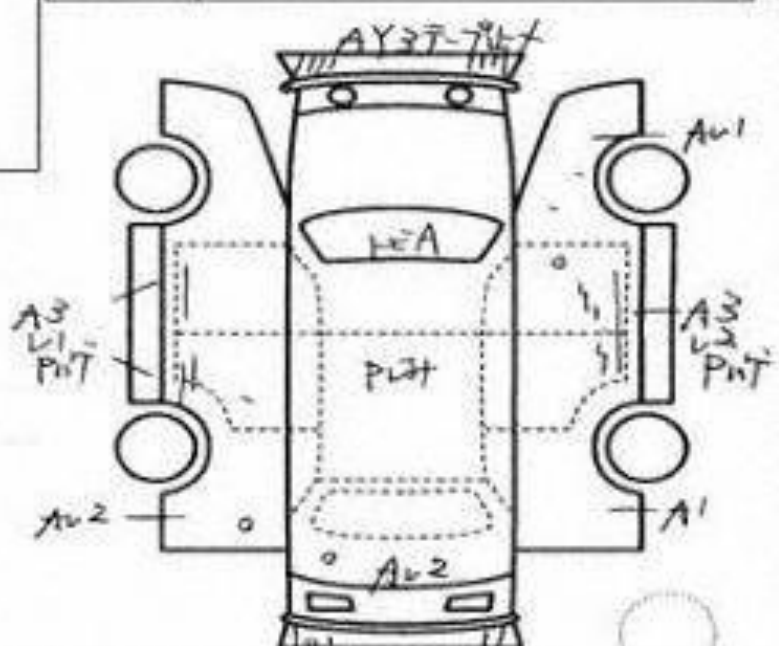

台内寸約	×	×	(cm)
長さ	cm	幅	cm
高さ	cm	← (車検証上の寸法) ズレ AY37-71x	

Please proceed to the next page to see English Translation of this auction sheet.

AUCTION SHEET ENGLISH TRANSLATION

Date: 2018- - Auction: USS Lot #:

Auction No.	Vehicle Use		Displacement	Grade	Grade	
[REDACTED]	Private		2500 cc	HIGHWAY STAR	3	
	Japan Y/M	Make/model	Model code	Door Style		
	2005/11	ELGRAND	CBA-MNE51	5		
				C	C	

Current Inspection (Year/month)		
N/A		
Mileage in Kms		
483 km		
original color	change color	color no:
BLACK		G30
Fuel		Interior color
GS (Gasoline)		
Seats	Drive type	Drive
8	4WD	RHD

Transmission
AT
Air condition
AC
Recycling deposit
¥15,980
Registration number
N/A
Chassis number
MNE51-[REDACTED]

Sun roof	Aluminum wheel	power steering	power window
-	-	✓	✓
Leather	TV	NAVI	Airbag
-	✓	✓	✓
Sales point			
<ul style="list-style-type: none"> ETC Back camera 			

BOX Key
Car name Elgrand ?

Inspector Report

- Some exterior scratches and dents
- Chips on the windscreen
- Paint spots on roof
- Tape on bumpers
- Left door mirror- cracks on turn signals
- Seats- torn, tapes
- Scuffed steering wheel
- Dirty, scratches in cabin
- Left power slide door- not working
- Scratches on wheels
- Rear spoiler- faded paint

Length	Width	Height
-	-	-

- A1** Small Scratch
- A2** Scratch
- A3** Big Scratch
- S** Rust
- U1** Small dents
- C1** Corrosion
- P** Paint faeded/burnt marks
- Y** Small Hole or Crack
- W2** Repair Mark/Wave

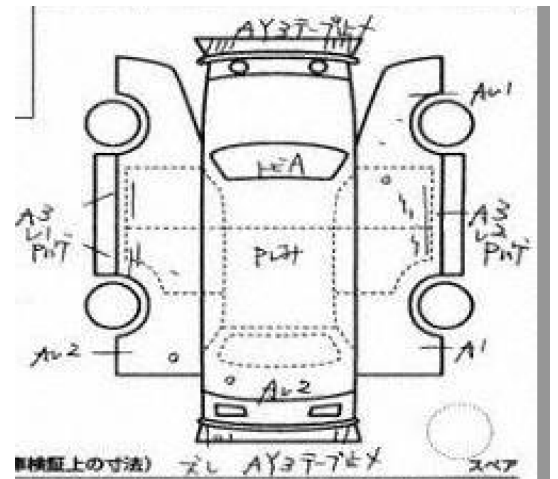

*Please proceed to the next page to see the full auction list explanation.

AUCTION LIST EXPLANATION

A1 Small Scratch

A2 Scratch

A3 Big Scratch

B Dent with scratch

B1 Distortion on (radiator) core support or back panel (approximately size of a thumb)

B2 Big Distortion on (radiator) core support or back panel

B1-B4 Large dents

C1 Corrosion

C2 Heavy Corrosion

AU2 Dent and Scratch (Medium).

E1 Few Dimples

E2 Several Dimples

E3 Many Dimples

G Stone chip in glass

H Paint faded or (Thumb size hole from rust, corrosion or rotting)

P Paint damaged marked

BP Panel beaten and re-painted

S1 Rust

S2 Heavy Rust

U1 Small Dent

U2 Dent

U3 Big Dent

Y1 Small Hole or Crack

Y2 Hole or Crack

Y3 Big Hole or Crack

X1 Small Crack on Windshield (approximately 1cm)

R Repaired Crack on Windshield

RX Repaired Crack on Windshield (needs to be replaced)

X Needs to be replaced or crack on glass

XX Replaced

W1 Repair Mark/Wave (hardly detectable)

W2 Repair Mark/Wave

W3 Obvious Repair Mark/Wave (needs to be repainted)

AUCTION GRADE EXPLANATION

6 / S New car

5 Used but appears as new

4.5 Very clean with only minor pin dents & scratches

4 Good condition with normal wear & tear

3.5 Numerous condition faults / possible minor repair

3 Poor condition / noticeable dents & damage / rust / past repair

2 Very poor condition / water damaged

1 Modified (usually performance parts)

0 Repaired

R Repaired (History of being repaired, parts replaced, no quality guarantee, buy at your risk, could be big damages, frame bent possibility.)

RA Accident repaired, been in crash, parts replaced, generally small damages.

******* Ungraded (existing fault / damage)

A - D Body / interior condition (**A – as new**, **B – very clean**, **C – average**, **D – poor**)

E – The car is in bad shape. Rust, corrosion and exterior breakdowns are plenty.



***Verified source (USS [redacted] - 2018-[redacted] - [redacted])



***Verified source (USS [REDACTED] - 2018-[REDACTED] - [REDACTED])

MANUFACTURE RECORDS FROM THE ORIGINAL MANUFACTURE

1	エルブランド
MODEL〈車種記号〉	ELGNRHKE51EZ8--DA-
グレード	ハイウェイスター
発表年月	2005/12
発売年月	2005/12 ~
エンジン	VQ25DE
駆動方式	4WD
トランスミッション	5AT
メーカーオプション※	情報無し

2	エルブランド
MODEL〈車種記号〉	ELGNRHKE51EZ8--DA-
グレード	ハイウェイスター
発表年月	2005/04
発売年月	2005/04 ~
エンジン	VQ25DE
駆動方式	4WD
トランスミッション	5AT
メーカーオプション※	情報無し

3	エルブランド
MODEL〈車種記号〉	ELGNRHKE51EZ8--DA-
グレード	ハイウェイスター
発表年月	2004/12
発売年月	2004/12 ~
エンジン	VQ25DE
駆動方式	4WD
トランスミッション	5AT
メーカーオプション※	情報無し

MANUFACTURE RECORDS (ENGLISH TRANSLATION)

1 Elgrand

MODEL <Vehicle type code>	ELGNRHKE51EZ8--DA-
grade	Highway Star
Announcement date	2005/12
Release date	2005/12 ~
engine	VQ25DE
Drive system	4WD
transmission	5AT
Manufacturer option *	No information

2 Elgrand

MODEL <Vehicle type code>	ELGNRHKE51EZ8--DA-
grade	Highway Star
Announcement date	2005/04
Release date	2005/04 ~
engine	VQ25DE
Drive system	4WD
transmission	5AT
Manufacturer option *	No information

3 Elgrand

MODEL <Vehicle type code>	ELGNRHKE51EZ8--DA-
grade	Highway Star
Announcement date	2004/12
Release date	2004/12 ~
engine	VQ25DE
Drive system	4WD
transmission	5AT
Manufacturer option *	No information

GLOSSARY

1 Chassis number: a unique identification number of the vehicle in Japan (same as VIN in the USA or Europe)

2 Safety grade: Determining the overall collision safety performance evaluation – For the driver's seat, the results of the full-wrap frontal collision test, offset frontal collision test, and side collision test are added together and evaluated to 6 different levels. For the Frontal passenger's seat, the results of the full-wrap frontal collision test and the side collision test (results for the driver's or the front passenger's seat are used) are added together and evaluated to 6 different levels.

3 Title information:

Registered – qualified for driving in Japan

Deregistered Temporarily – not qualified for driving in Japan, usually a temporary title during the ownership change

Deregistered Completely – not qualified for driving in Japan, the vehicle is determined to be scrapped

Deregistered to Export – not qualified for driving in Japan, the vehicle is determined to be exported

4 Use in the contaminated regions: The Fukushima Daiichi nuclear disaster was a catastrophic failure at the Fukushima I Nuclear Power Plant on 11 March 2011, resulting in a meltdown of three of the plant's six nuclear reactors. As a result, some areas in the following prefectures were contaminated: Fukushima, Miyagi, Ibaraki, Tochigi.

5 Radioactive contamination test: radioactive contamination inspection that was started in July 2011 as a preventive measure for exporting contaminated vehicles from Japan. The inspection is being conducted since in all sea ports of Japan under the supervision of The Japan Harbor Transportation Association (JHTA).

MLIT – Ministry of Land, Infrastructure, Transport and Tourism.

AUTOCHECK.JP DEPENDS ON ITS SOURCES FOR THE ACCURACY AND RELIABILITY OF ITS INFORMATION. THEREFORE, NO RESPONSIBILITY IS ASSUMED BY AUTOCHECK.JP OR ITS AGENTS FOR ERRORS OR OMISSIONS IN THIS REPORT. AUTOCHECK.JP FURTHER EXPRESSLY DISCLAIMS ALL WARRANTIES, EXPRESS OR IMPLIED, INCLUDING ANY IMPLIED WARRANTIES OF MERCHANTABILITY OR FITNESS FOR A PARTICULAR PURPOSE.