

1999 SUBARU IMPREZA WRX R STI VI LIMITED

 Report created by hand on 2021/██████

VEHICLE DETAILS

Auction	US\$ ██████
Auction date	2020- ██████
Lot number	██████
Chassis ID/VIN	GC8- ██████
Make	SUBARU
Model	IMPREZA
Mileage	██████ , 151 km
Engine CC	2000 (2.0L)
Year	1999/11
Grade/Trim	WRX R STI VI LIMITED
Inspection	N/A
Equipment	AC
Transmission	F5
Start price	¥480,000
Finish price	Unavailable
Color	BLUE
Condition	3
Status	Unknown

GRADE

3

AUTOCHECK GRADING

Poor condition

The Autocheck grading scheme is based on standard Japanese auction grading system. It lets you compare similar vehicles with ease.



Auction grade

3 Poor condition



Accident / Repair

No problem found



Mileage report

High mileage



Use history

Private Car



Stolen check

No stolen status



AUTOCHECK FACTS

Auction grade



Poor condition / noticeable dents & damage / rust / past repair

Odometer check



No Odometer tampering reported

NOTE: This Autocheck Vehicle History Report is based only on Information supplied to Autocheck CO. and available as of 2021-02-16 15:12:25. Other information about this vehicle, including problems, may not have been reported to Autocheck CO. Use this report as one important tool, along with a vehicle inspection and test drive, to make a better decision about your next Japanese used car.

✓ ACCIDENT / REPAIR HISTORY (JAPAN)

Type of record	Reported event	Reported date	Source	Details	Airbag
Collision	✓ Not reported				
Malfunction	✓ Not reported				
Theft	✓ Not reported				
Fire damage	✓ Not reported				
Water damage	✓ Not reported				
Hail damage	✓ Not reported				

REPORTED ODOMETER HISTORY

Reported date	Kilometres	Source
2020-██	██, 151 km	USS █

✓ USE HISTORY (JAPAN)

Use in the contaminated regions ⁴	Radioactive contamination test fail ⁵	Commercial use
Not reported	Not reported	Not reported

✓ MANUFACTURE RECALL HISTORY

Date	Source	Affected part	Details
No recall records found.			

AUCTION SHEETS & PHOTOS

Date: 2020- [redacted], Auction: USS [redacted], Lot #: [redacted]

M Tコーナー

[redacted]	車種 (自動車以外は記入)	排気量	型式	評価点 3
		2000	GF-GC8	
	初年度登録年月	車名	グレード	2WD
	12/7月	インプレッサ	WRX STi	2WD
		209	パワウィンド	4WD
				内装 B

車検	年	月	シフト	F5	燃費	S R	AW	ナビ	エア
走行	[redacted]	151	Km	マイル	冷房	AC	カワ	TV	ナビ
外色	ブルー	色番	74F	カラー	有・無	セールスポイント ★ユーザ買取車 ★クーパボディ ★ルーフハンチング			
燃料	ガソリン	軽油	()	内装色	名義変更期限 月 日				
車種	輸入区分	ハンドル	ディーラー並行 左・右						

リサイクル 預託金	10990円	車検定員	人	登録地	[redacted]
○注意事項 (補償・不具合箇所および状態等)				車台地	GC8-[redacted]
お外ハンドル 記録簿 (有)				シリアル地	[redacted]

○検査員報告 (USS使用欄)

内装スリッパ ✓ 左フールミナルBP
ルーフP7E
ドア取付部P7E
スポンジP7E 小P7E
下廻りP7E P7E
各口P7E

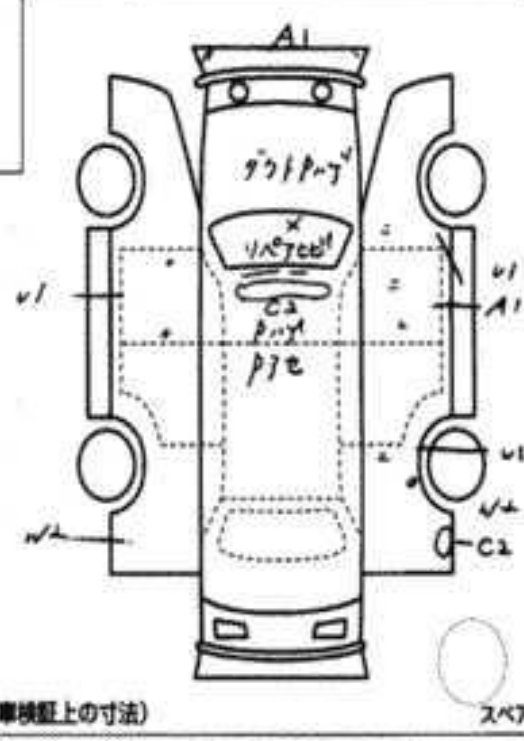

台内寸約	X	X	(cm)
長さ	cm	幅	cm
		高さ	cm

← (車検証上の寸法) スペア

Please proceed to the next page to see English Translation of this auction sheet.

AUCTION SHEET ENGLISH TRANSLATION

Date: 2020- , Auction: USS , Lot #:

Auction No.	Vehicle Use		Displacement	Grade	Grade	
 	Private		2000 cc	WRX R TYPE STI VERSION 6 LTD	3	
	Japan Y/M	Make/model	Model code	Door Style	Exterior	Interior
	2000/7	IMPREZA	GF-GC8	2CP	B	B

Current Inspection (Year/month)		
N/A		
Mileage in Kms		
 151 km		
original color	change color	color no:
BLUE		74F
Fuel		Interior color
GS (Gasoline)		
Seats	Drive type	Drive
	4WD	RHD
Notice		

Maitanance record book
Nested steering

Transmission
F5
Air condition
AC
Recycling deposit
¥10,990
Registration number
N/A
Chassis number
GC8-

Sun roof	alloy wheel	power steering	power window
-	-	✓	✓
Leather	TV/Navi	ABS	Airbag
-	-	-	-
Sales point			
<ul style="list-style-type: none"> ★ User purchased Car ★ Cooper body ★ Roof ventilator 			

Inspector Report

Small thin line scratches on Exterior **A1**
 Light repair mark/waves on exterior
 Slightly dirty interior
 Door mirror scratch
 roof paint faded
 Small crack on windshield
 Steering wheel thread
 Seat thread
 Under part small rust
 Left side light panel beaten/repaint history BP

Length	Width	Height
-	-	-

- A1** Small Scratch
- A2** Scratch
- A3** Big Scratch
- S** Rust
- U** Small dents
- B1** Small dent, B3 large dent
- G** Stone chip in glass
- X** Part exchange required
- XX** Part exchange history

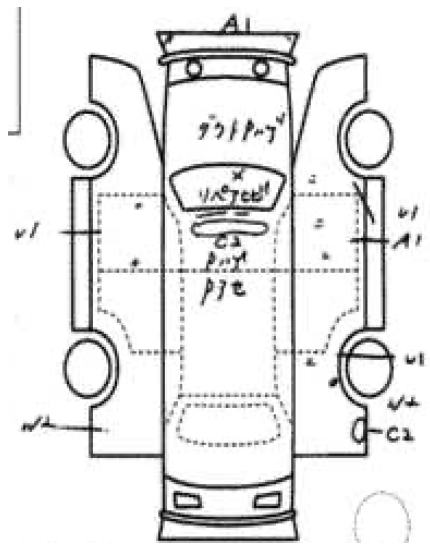

*Please proceed to the next page to see the full auction list explanation.

AUCTION LIST EXPLANATION

A1 Small Scratch	S1 Rust
A2 Scratch	S2 Heavy Rust
A3 Big Scratch	U1 Small Dent
B Dent with scratch	U2 Dent
B1 Distortion on (radiator) core support or back panel (approximately size of a thumb)	U3 Big Dent
B2 Big Distortion on (radiator) core support or back panel	Y1 Small Hole or Crack
B1-B4 Large dents	Y2 Hole or Crack
C1 Corrosion	Y3 Big Hole or Crack
C2 Heavy Corrosion	X1 Small Crack on Windshield (approximately 1cm)
AU2 Dent and Scratch (Medium).	R Repaired Crack on Windshield
E1 Few Dimples	RX Repaired Crack on Windshield (needs to be replaced)
E2 Several Dimples	X Needs to be replaced or crack on glass
E3 Many Dimples	XX Replaced
G Stone chip in glass	W1 Repair Mark/Wave (hardly detectable)
H Paint faded or (Thumb size hole from rust, corrosion or rotting)	W2 Repair Mark/Wave
P Paint damaged marked	W3 Obvious Repair Mark/Wave (needs to be repainted)
BP Panel beaten and re-painted	

AUCTION GRADE EXPLANATION

6 / S New car	0 Repaired
5 Used but appears as new	R Repaired (History of being repaired, parts replaced, no quality guarantee, buy at your risk, could be big damages, frame bent possibility.)
4.5 Very clean with only minor pin dents & scratches	RA Accident repaired, been in crash, parts replaced, generally small damages.
4 Good condition with normal wear & tear	*** Ungraded (existing fault / damage)
3.5 Numerous condition faults / possible minor repair	A - D Body / interior condition (A – as new , B – very clean , C – average , D – poor)
3 Poor condition / noticeable dents & damage / rust / past repair	E – The car is in bad shape. Rust, corrosion and exterior breakdowns are plenty.
2 Very poor condition / water damaged	
1 Modified (usually performance parts)	



Verified photos (Source: USS [redacted])



Verified photos (Source: USS [REDACTED])

MANUFACTURE RECORDS

Manufacture details from Original Manufacture

IMPREZA SPORTS COUPE

MODEL(車種記号)	GC8G2FD 45C
車両型式	GF-GC8
グレード	WRX type R STi Version VI Limited
発売年月	1999/11
エンジン	2000 DOHC ターボ
駆動方式	AWD
トランスミッション	5MT

(ENGLISH TRANSLATION)

Impreza SPORTS WAGON

MODEL(Model code)	GC8G2FD 45C
Vehicle model	GF-GC8
Grade	WRX type R STi Version VI Limited
Manufacture date	1999/11
Engine	2000 DOHC ターボ
Drive system	AWD
Transmission	5MT

GLOSSARY

1 Chassis number: a unique identification number of the vehicle in Japan (same as VIN in the USA or Europe)

2 Safety grade: Determining the overall collision safety performance evaluation – For the driver's seat, the results of the full-wrap frontal collision test, offset frontal collision test, and side collision test are added together and evaluated to 6 different levels. For the Frontal passenger's seat, the results of the full-wrap frontal collision test and the side collision test (results for the driver's or the front passenger's seat are used) are added together and evaluated to 6 different levels.

3 Title information:

Registered – qualified for driving in Japan

Deregistered Temporarily – not qualified for driving in Japan, usually a temporary title during the ownership change

Deregistered Completely – not qualified for driving in Japan, the vehicle is determined to be scrapped

Deregistered to Export – not qualified for driving in Japan, the vehicle is determined to be exported

4 Use in the contaminated regions: The Fukushima Daiichi nuclear disaster was a catastrophic failure at the Fukushima I Nuclear Power Plant on 11 March 2011, resulting in a meltdown of three of the plant's six nuclear reactors. As a result, some areas in the following prefectures were contaminated: Fukushima, Miyagi, Ibaraki, Tochigi.

5 Radioactive contamination test: radioactive contamination inspection that was started in July 2011 as a preventive measure for exporting contaminated vehicles from Japan. The inspection is being conducted since in all sea ports of Japan under the supervision of The Japan Harbor Transportation Association (JHTA).

MLIT – Ministry of Land, Infrastructure, Transport and Tourism.

AUTOCHECK.JP DEPENDS ON ITS SOURCES FOR THE ACCURACY AND RELIABILITY OF ITS INFORMATION. THEREFORE, NO RESPONSIBILITY IS ASSUMED BY AUTOCHECK.JP OR ITS AGENTS FOR ERRORS OR OMISSIONS IN THIS REPORT. AUTOCHECK.JP FURTHER EXPRESSLY DISCLAIMS ALL WARRANTIES, EXPRESS OR IMPLIED, INCLUDING ANY IMPLIED WARRANTIES OF MERCHANTABILITY OR FITNESS FOR A PARTICULAR PURPOSE.