

2003 SUBARU IMPREZA WRX STI (SAMPLE)

Report generated on 2020-03-09

VEHICLE DETAILS

Data Source	
Reported date	
Lot number	
Chassis ID	GDB-XXXXXX
Make	SUBARU
Model	IMPREZA WRX
Mileage	
Engine CC	2000
Year	2003
Grade	WRX STI
Inspection	N/A
Equipment	AAC
Transmission	F6
Start price	¥0
Finish price	N/A (sold with nego)
Color	BLUE
Condition	4
Status	N/A (sold with nego)

GRADE

4

AUTOCHECK GRADING

Average condition

The Autocheck grading scheme is based on standard Japanese auction grading system. It lets you compare similar vehicles with ease.



Auction grade

Average condition



Accident / Repair

No accidents or repairs.

(* hardly noticeable minor repair *)



Mileage report

High mileage



Use history

Private/Normal



Stolen check

No stolen status



AUTOCHECK FACTS

Auction grade



Average condition

Mileage & Use history



Private usage

NOTE: This Autocheck Vehicle History Report is based only on Informn supplied to Autocheck CO. and available as of 2020-03-09 13:29:10. Other information about this vehicle, including problems, may not have been reported to Autocheck CO. Use this report as one important tool, along with a vehicle inspection and test drive, to make a better decision about your next Japanese used car.

✓ HISTORY RECORDS (JAPAN)

Type of record	Reported event	Reported date	Source	Details	Airbag
Accident/Repair	✗ Reported				
Malfunction	✓ Not reported				
Theft	✓ Not reported				
Fire damage	✓ Not reported				
Water damage	✓ Not reported				
Hail damage	✓ Not reported				

REPORTED ODOMETER HISTORY

Reported date	Kilometres	Source

✓ USE HISTORY (JAPAN)

Use in the contaminated regions ⁴	Radioactive contamination test fail ⁵	Commercial use
Not reported	Not reported	Not reported

MANUFACTURE RECALL HISTORY

Date	Source	Affected part	Details
No records found.			

M Tコーナー

車歴 (自家用以外は記入)	排気量	型式	評価点 4
	2000	GH-GDB	
初度登録年月	車名	駆動方式	内装 C
15/2月	インプレッサ WRX	4WD	
		グレード	
		STi	

車検	年	月	シフト	変速機	S R	AW	PS	PW
			F6		カワ	TV	ナビ	CD
走行			冷房	セルスポイント				
			ACC	★加減り3タイプ				
外色	元色	色番	カラー貼	★純正OP BBS				
ブルー			020	★DCCD				
燃料	ガソリン・軽油・()		内装色	★大型リアスポイラー				
型式	輸入区分	ハンドル	名義変更期間					
	ディーラー・並行	左・右	月 日					

リサイクル 預託金	12990 円	乗車定員	5人	登録地	
--------------	---------	------	----	-----	--

◎注意事項 (修理・不具合箇所および状態等)

- ★ エンジン買収車
- ★ グレボキリパー
- ★ HIDヘッドライト
- ★ レジスタリング
- ★ フロントTV
- ★ ETC

◎検査員報告 (USS使用欄)

プレインユニット預り
 内装汚れ、スリ、コゲ
 ハンドル汚れ
 ディスタンス、汚れ
 外AW スタッドレス
 Rスポング
 下回りサビ

※ (車検経上の寸法)

台内寸約	X	X	(cm)
長さ	cm	幅	cm
高さ	cm		

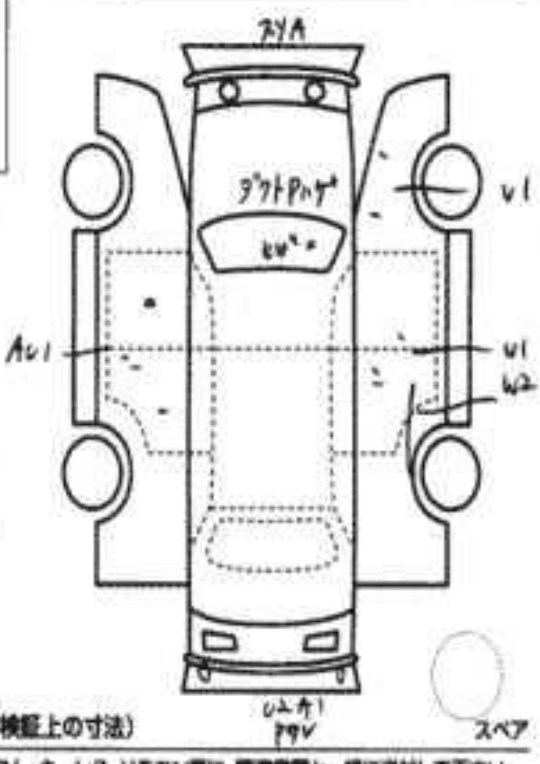

CONDITION SHEET ENGLISH TRANSLATION

Auction No.	Vehicle Use		Displacement	Grade	Grade	
	Private use		2000 cc	STI	4	
	Japan Y/M	Make/model	Model code	Door Style	Exterior	Interior
	2003/6	IMPREZA WRX	GH-GDB	4	C	C

Current Inspection (Year/month)		
N/A		
Mileage in Kms		
[REDACTED]		
original color	change color	color no:
BLUE		20
Fuel		Interior color
Petrol		Black
Seats	Drive type	Drive
5	2WD	RHD
Notice		

*Chapter 1

HID light

MD or CD changer/TV

ETC

Transmission
F6
Air condition
AAC
Recycling deposit
¥2,990
Registration
[REDACTED]
Chassis number
[REDACTED]

sunroof	alloy wheel	power steering	power window
-	✓	✓	✓
Leather	ABS	TV/Navi	Airbag
-	-	-	✓
Sales point			
FIRST TIME AUCTION			
Navigation - Digital TV			
Back monitor - ETC			

Inspector Report

Small scratches

Cigarette burned holes on the Carpet

Under the Bumper (A)

Rear bumper under (A)

Outside AW studless tires

R Sport*

A Scratch or crack

B Large Dent

G Stone chip in glass

S Rust

U Dent

AU Scratch & Dent

W2 Repair History (Repair Mark/Wave)

P/V Paint damaged marked

XX Part exchange history

Length	Width	Height
-	-	-

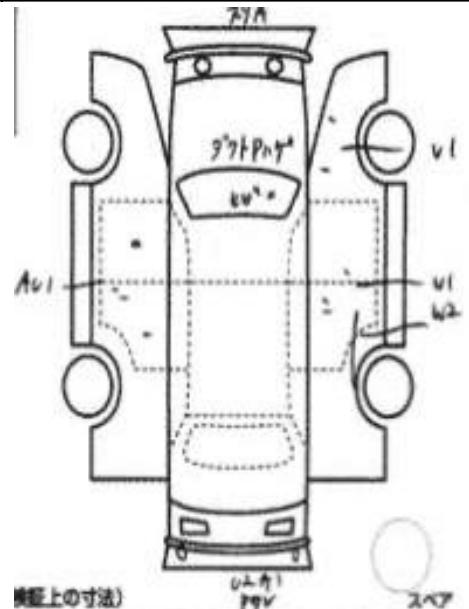

CONDITION SHEET EXPLANATION

A1 Small Scratch	S1 Rust
A2 Scratch	S2 Heavy Rust
A3 Big Scratch	U1 Small Dent
B Dent with scratch	U2 Dent
B1 Distortion on (radiator) core support or back panel (approximately size of a thumb)	U3 Big Dent
B2 Big Distortion on (radiator) core support or back panel	Y1 Small Hole or Crack
B1-B4 Large dents	Y2 Hole or Crack
C1 Corrosion	Y3 Big Hole or Crack
C2 Heavy Corrosion	X1 Small Crack on Windshield (approximately 1cm)
AU2 Dent and Scratch (Medium).	R Repaired Crack on Windshield
E1 Few Dimples	RX Repaired Crack on Windshield (needs to be replaced)
E2 Several Dimples	X Needs to be replaced or crack on glass
E3 Many Dimples	XX Replaced
G Stone chip in glass	W1 Repair Mark/Wave (hardly detectable)
H Paint faded or (Thumb size hole from rust, corrosion or rotting)	W2 Repair Mark/Wave
P Paint damaged marked	W3 Obvious Repair Mark/Wave (needs to be repainted)

AUCTION GRADE EXPLANATION

6 / S New car	0 Repaired
5 Used but appears as new	R Repaired (History of being repaired, parts replaced, no quality guarantee, buy at your risk, could be big damages, frame bent possibility.)
4.5 Very clean with only minor pin dents & scratches	RA Accident repaired, been in crash, parts replaced, generally small damages.
4 Good condition with normal wear & tear	*** Ungraded (existing fault / damage)
3.5 Numerous condition faults / possible minor repair	A - D Body / interior condition (A – as new , B – very clean , C – average , D – poor)
3 Poor condition / noticeable dents & damage / rust / past repair	E – The car is in bad shape. Rust, corrosion and exterior breakdowns are plenty.
2 Very poor condition / water damaged	
1 Modified (usually performance parts)	



** Verified Photos



GLOSSARY

1 Chassis number: a unique identification number of the vehicle in Japan (same as VIN in the USA or Europe)

2 Safety grade: Determining the overall collision safety performance evaluation – For the driver's seat, the results of the full-wrap frontal collision test, offset frontal collision test, and side collision test are added together and evaluated to 6 different levels. For the Frontal passenger's seat, the results of the full-wrap frontal collision test and the side collision test (results for the driver's or the front passenger's seat are used) are added together and evaluated to 6 different levels.

3 Title information:

Registered – qualified for driving in Japan

Deregistered Temporarily – not qualified for driving in Japan, usually a temporary title during the ownership change

Deregistered Completely – not qualified for driving in Japan, the vehicle is determined to be scrapped

Deregistered to Export – not qualified for driving in Japan , the vehicle is determined to be exported

4 Use in the contaminated regions: The Fukushima Daiichi nuclear disaster was a catastrophic failure at the Fukushima I Nuclear Power Plant on 11 March 2011, resulting in a meltdown of three of the plant's six nuclear reactors. As a result, some areas in the following prefectures were contaminated: Fukushima, Miyagi, Ibaraki, Tochigi.

5 Radioactive contamination test: radioactive contamination inspection that was started in July 2011 as a preventive measure for exporting contaminated vehicles from Japan. The inspection is being conducted since in all sea ports of Japan under the supervision of The Japan Harbor Transportation Association (JHTA).

MLIT – Ministry of Land, Infrastructure, Transport and Tourism.

AUTOCHECK.JP DEPENDS ON ITS SOURCES FOR THE ACCURACY AND RELIABILITY OF ITS INFORMATION. THEREFORE, NO RESPONSIBILITY IS ASSUMED BY AUTOCHECK.JP OR ITS AGENTS FOR ERRORS OR OMISSIONS IN THIS REPORT. AUTOCHECK.JP FURTHER EXPRESSLY DISCLAIMS ALL WARRANTIES, EXPRESS OR IMPLIED, INCLUDING ANY IMPLIED WARRANTIES OF MERCHANTABILITY OR FITNESS FOR A PARTICULAR PURPOSE.